

Power Driving

- Chrome vanadium alloy steel
- Anti-rust oiled, sand-blasted

1/4" & 3/8" & 1/2"
Hex size shank driver



76B

- Deep well nut setter
- Deep hole for bolt & nut
- Press-fitted high-durability shank
- Use for tightening step clamp in construction

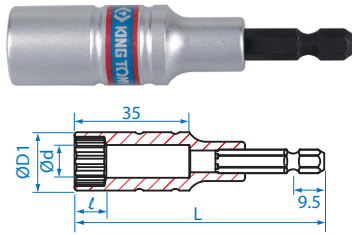

KT NO.	mm	D1 mm	ℓ mm	d mm	L mm	g	kg	boxes
76B808M	8	13	6	6	80	41	15	300
76B809M	9	13	6	7	80	40	15	300
76B810M	10	15	7	7	80	47	12	240
76B811M	11	16	7	9	80	52	12	240
76B812M	12	17	8	9	80	57	12	240
76B813M	13	18	9	10	80	62	12	240
76B814M	14	20	9	12	80	70	12	240
76B815M	15	21	10	12	80	77	12	240
76B816M	16	22	10	14	80	76	12	240
76B817M	17	24	11	14	80	95	12	144
76B819M	19	26	13	15	80	112	10	120
76B821M	21	28	13	19	80	113	10	120
76B822M	22	30	13	19	80	137	10	120
76B824M	24	32	13	21	80	146	6	96

76C

- 110mm length easy to reach at confined spaces
- Extra depth dimension 63mm perfectly go through various bolts
- Press-fit structure with durability socket suitable for 18V power tools
- Ideal for construction assembling, scaffolding and roof work

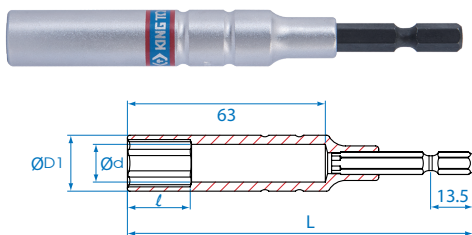

KT NO.	mm	D1 mm	ℓ mm	d mm	L mm	g	kg	boxes
76C1108M	8	14.0	12	7	110	71	12	216
76C1109M	9	14.0	14	8	110	64	12	216
76C1110M	10	15.0	15	9	110	67	12	216
76C1111M	11	17.0	17	10	110	84	10	180
76C1112M	12	17.0	18	11	110	74	10	180
76C1113M	13	18.0	20	12	110	79	10	180
76C1114M	14	20.0	21	13	110	99	10	180
76C1117M	17	24.0	26	16	110	139	10	180
76C1119M	19	26.0	29	18	110	158	10	180
76C1121M	21	28.0	30	20	110	161	8	144
new 76C1123M	23	29.8	30	22	110	200	8	96
76C1124M	24	32.0	30	23	110	216	8	96

770

- Socket adapter
- Ball retainer type
- DIN 7428

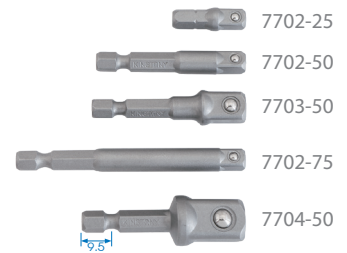

KT NO.	Size	Overall length (mm)	g	kg	boxes
7702-25	1/4"	25	6	20	200
7702-50	1/4"	50	13	10	100
7702-75	1/4"	75	23	10	100
7703-50	3/8"	50	23	6	84
7704-50	1/2"	50	24	6	72

774

- Bit adapter
- Wobble function provides up to 15° accessibility

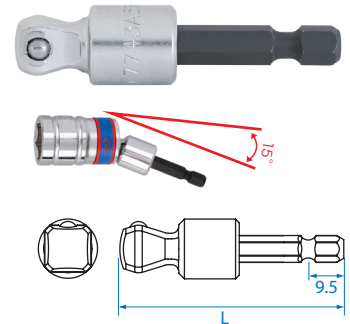

KT NO.	Size	L mm	g	kg	boxes
7743-56	3/8"	56	30	6	72
7744-60	1/2"	60	42	6	72

